

Belt Sway Detection and Correcting Equipment
Motor-Operated Adjusting Carrier

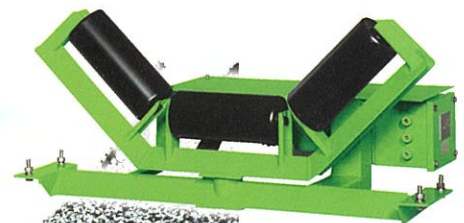

Model HAB-MC

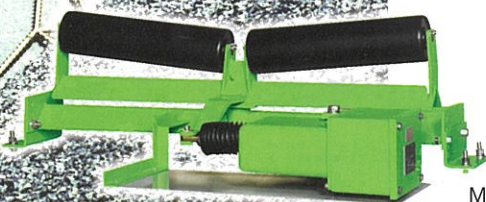

Model HAB-MR



Detector
Model HBVL-5□

Automatically adjusts the conveyor belt to correct deviation or sway

Swaying of the conveyor belt causes loads to fall and conveyor belt damage.

An adjustment of the conveyor belt is the only way to correct this swaying.

Matsushima's Motor-Operated Adjusting Carrier detects conveyor belt sway and automatically corrects it, greatly reducing the time and cost needed for operation control and maintenance.



Features

Ideal protection for your materials, your products and your conveyor belt

Falling loads and the resulting accidents can be prevented.

As an additional benefit, your conveyor belt life is extended because the breakage and damage caused by swaying and twisting is prevented.

Easy installation and maintenance

The Motor-Operated Adjusting Carrier requires no extra installation space. It can easily be mounted on your conveyor, and is built to operate even under severe environmental conditions. The Motor-Operated Adjusting Carrier replaces conventional manual adjustment and simplifies conveyor belt maintenance.

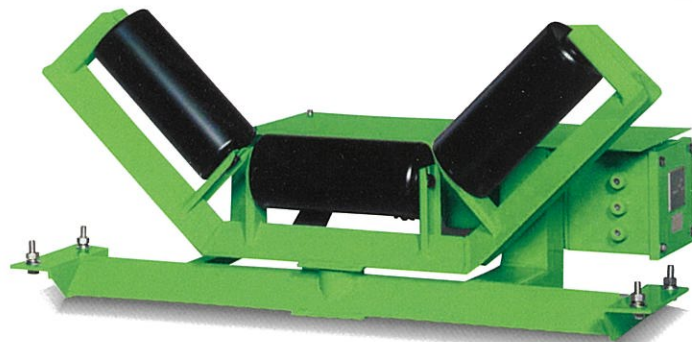

Carrier side mounting type
Model HAB-MC

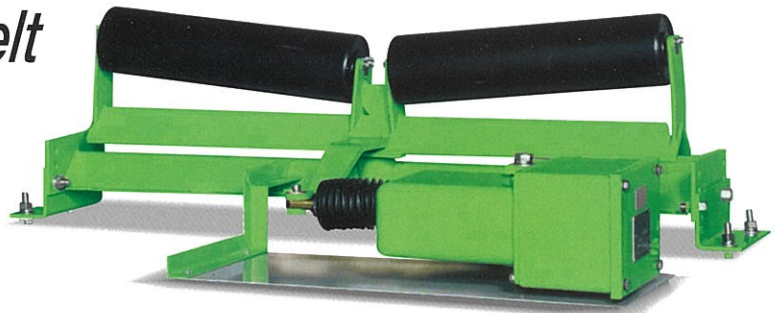

Return side mounting type
Model HAB-MR



Detector
Model HBVL-5
H : Hold type
A : Automatic reset type

Operation Principles of Motor-Operated Adjusting Carrier (With Hold Type Detector)

Operation Principles

1. When the conveyor belt sways, the belt edge pushes the touch pulley into a slanted position. Then, the potentiometer in the detector rotates at an angle in proportion to the pulley slant angle, and the microswitch in the detector operates to specify the direction for correction at the same time.
2. The positioner in the motor actuator compares the potentiometer resistance value of the detector with that of the motor actuator, and operates the motor actuator to turn the adjusting carrier in a direction that agrees with the potentiometer resistance value of the motor actuator to correct the sway.
3. The adjusting carrier maintains the slant angle after the conveyor belt position has been corrected and the belt edge is no longer in contact with the touch pulley. If the conveyor belt sways in the same direction again, the adjusting carrier will automatically move to correct the belt sway.
4. If the conveyor sways in the opposite direction, the adjusting carrier will turn in the reverse direction to adjust the conveyor belt, correcting the sway at the moment the belt edge pushes against the touch pulley on the other side to slant it.

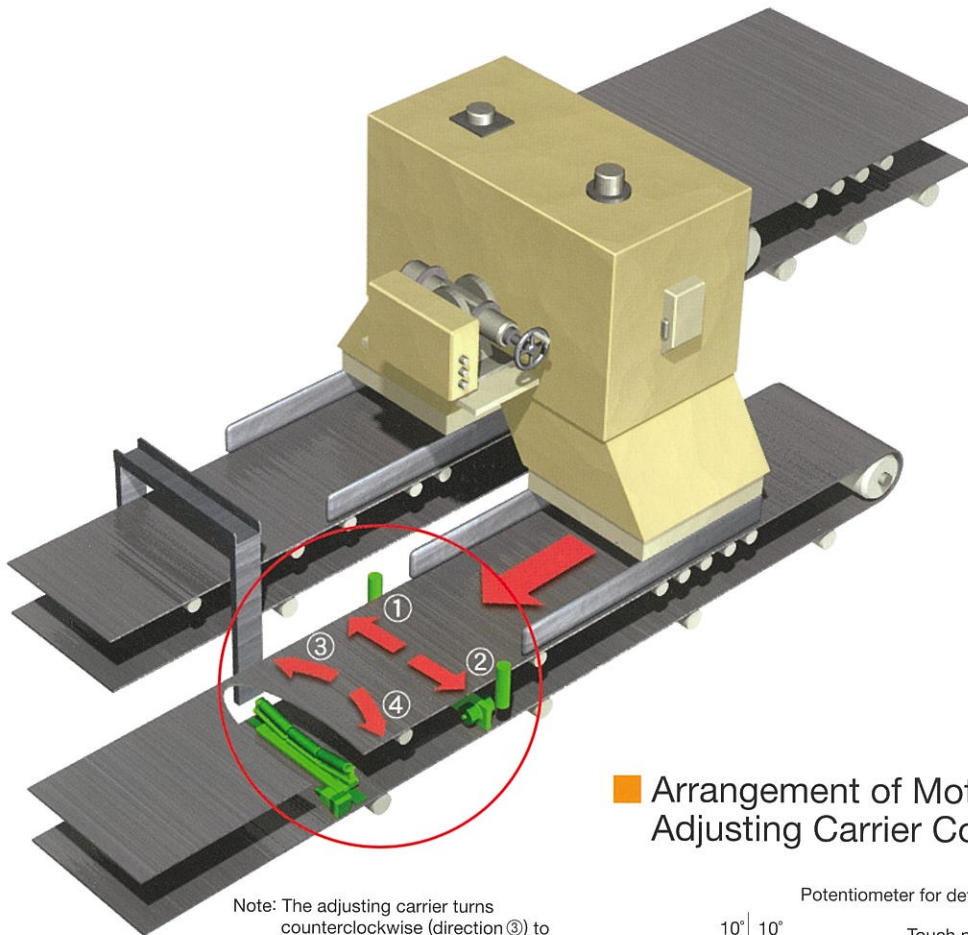

Note: The adjusting carrier turns counterclockwise (direction ③) to correct the deviation when the conveyor belt deviates (sways) in direction ① shown in the figure above, and turns clockwise (direction ④) when the belt deviates in direction ②.

Arrangement of Motor-Operated Adjusting Carrier Components

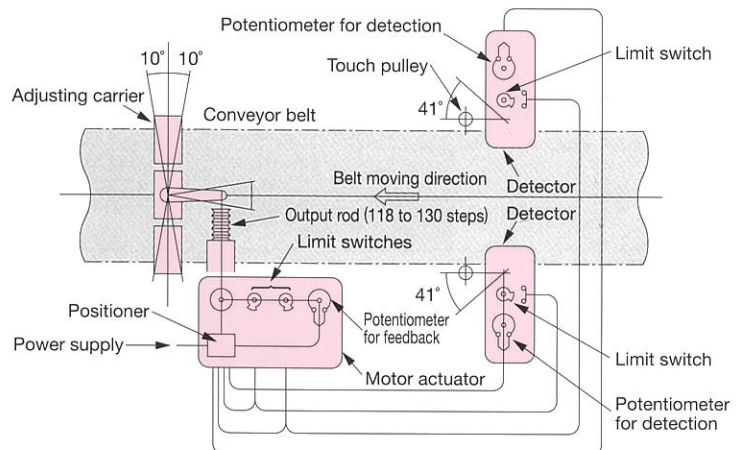

Application Example

Constant Feed Weigher (CFW) (Constant Feeder)

In iron and steel plants or cement plants, a constant feeder is attached to the bottom of the hopper to remove a constant amount of material from the hopper. This feeder uses a flat belt, and flat belts characteristically sway under certain operation and maintenance conditions. As a result, the belt edge frequently suffers damage caused by rubbing against the detection arm of the load cell. The only way to solve this problem is by the position adjustment of tail pulley bearings

while the conveyor is still running. This adjustment must be completed quickly, or humidity will cause the materials to stick to the belt and the conveyor frame will warp.

The return side mounting type Motor-Operated Adjusting Carrier is widely used in iron and steel plants as well as cement plants to correct conveyor belt sway, and has proven results in the reduction of maintenance costs, prevention of accidents, and reliable performance.

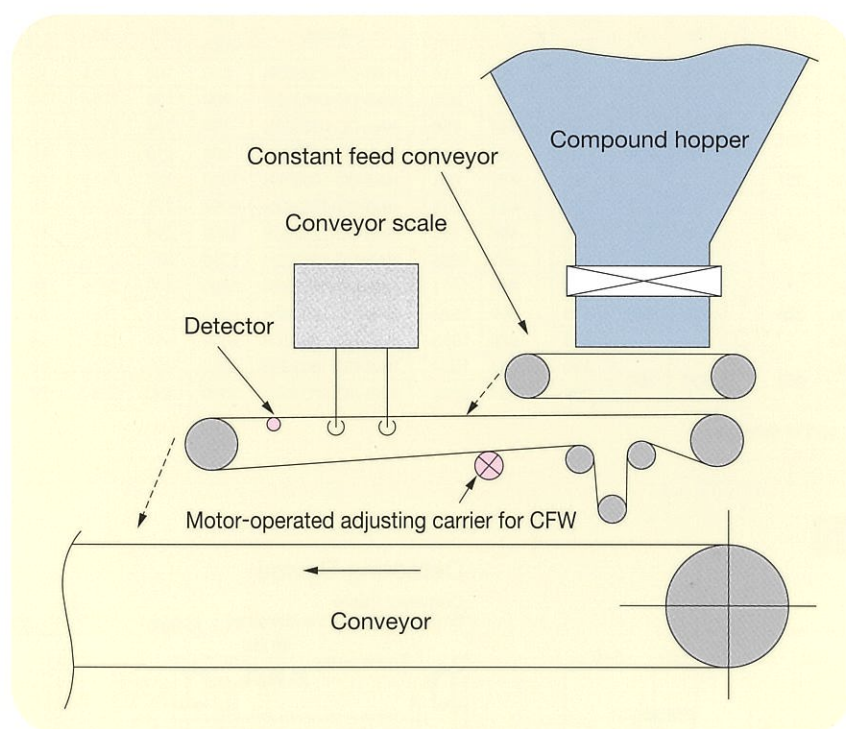

Motor Actuator

Item	Specifications
Enclosure	IP55
Allowable Temperature	-10 °C to 50 °C
Supports	Trunnions
Joints	Clevis brackets
Stroke	118 mm for normal operation
Speed	197/236 mm/min. (50/60 Hz)
Operating Time	36/30 s (50/60 Hz) (with normal stroke)
Force	1.76 kN (180 kgf)
Position Limit Switches	One each for forward limit and backward limit
Potentiometer	For position feedback (1 kΩ)
Driving Motor	Reversible motor (400 W 30 min. rating)
Positioner	Non-contact type, with operation status indicator lamp
Space Heater	20 W, 7 kΩ (for prevention of internal condensation)
Thermal Relay	With thermal trip contact signal
Power Supply	200 V (100 V) 50/60 Hz
Power Consumption	65 W

The potentiometer output is only for detection and cannot be used externally.

Adjusting Carrier

Item	Specifications
Applicable Conveyor Belt Width	500 mm to 2000 mm
Applicable Conveyor Speed	250 m/min. max.
Trough Angle*	20°, 30°, 45°
Max. Operating Angle	±10°

*: No trough angle on the return side
(Standard trough angle: 30°)

Detector

Item	Specifications
Enclosure	IP67
Allowable Temperature	-10 °C to 50 °C
Slant Angle of Touch Pulley	41° max.
Potentiometer	For detection of conveyor sway angle (1 kΩ)
Position Limit Switch	Set angle: 3°
Gear Ratio	3/1
Connection Cable	5-core CWV (Control-use, vinyl-insulated, vinyl-sheathed) cable: 1.25 mm ² × 5 m

External Dimensions in mm

Carrier side mounting type

Actuating Device

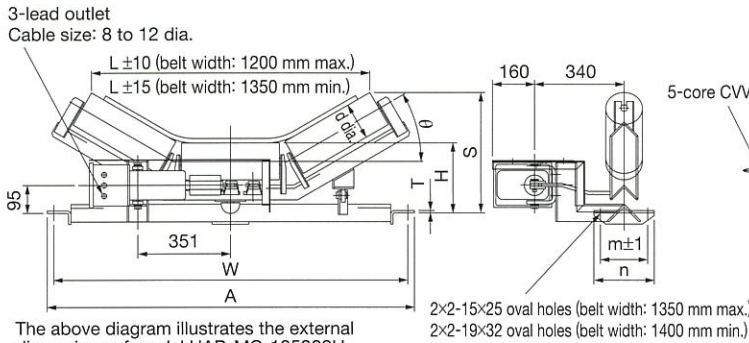

The above diagram illustrates the external dimensions of model HAB-MC-105302H (belt width: 1050 mm, trough angle: 30°).

Detecting Device

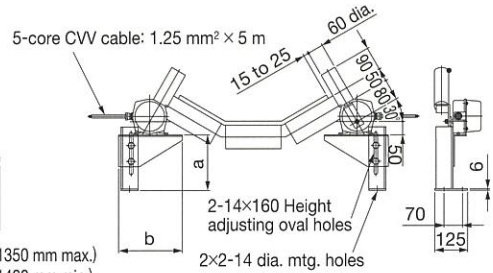

Model	Belt width	d dia.	W	A	H	T	m	n	Mass (kg)	$\theta=30^\circ$		Model	Belt width	a*	b*	Mass (kg)
										S*	L*					
HAB-MC-050□□2H	500	89.1	740	790	170	4.5	140	190	75	263	518	HAB-DC-050302H	500	106	201.5	13
HAB-MC-060□□2H	600		840	890	185		150	200	80	293	600	HAB-DC-060302H	600	136	210.5	14
HAB-MC-075□□2H	750		1040	1090	207		6	160	210	85	344	756	HAB-DC-075302H	750	184	218.5
HAB-MC-090□□2H	900	1190	1240	90		369				893	HAB-DC-090302H	900	210	226.5	15	
HAB-MC-100□□2H	1000	114.3	1290	1340	237	9	180	230	95	431	998	HAB-DC-100302H	1000	227	231.5	16
HAB-MC-105□□2H	1050		1340	1390	100				441	1053	HAB-DC-105302H	1050	275	232.5	16	
HAB-MC-120□□2H	1200		1490	1540	250				105	466	1190	HAB-DC-120302H	1200	299	239.5	17
HAB-MC-135□□2H	1350	139.8	1640	1690	333	280	340	175	160	491	1326	HAB-DC-135302H	1350	321	245.5	17
HAB-MC-140□□2H	1400		1730	1790					165	589	1414	HAB-DC-140302H	1400	412	266.5	18
HAB-MC-150□□2H	1500		1830	1890					175	609	1523	HAB-DC-150302H	1500	417	284.5	18
HAB-MC-160□□2H	1600	165.2	1930	1990	363	330	390	240	200	629	1633	HAB-DC-160302H	1600	441	275.5	18
HAB-MC-180□□2H	1800		2220	2280					240	694	1824	HAB-DC-180302H	1800	523	327.5	19
HAB-MC-200□□2H	2000		2420	2480					260	734	2042	HAB-DC-200302H	2000	533	336.5	20

*: The dimensions of motor actuators S and L and of detectors a and b depend on the trough angle.

Return side mounting type

Actuating Device

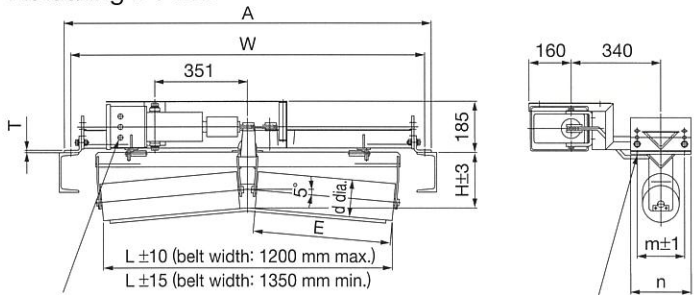

The above diagram illustrates the external dimensions of model HAB-MR-105052H (belt width: 1050 mm).

Detecting Device

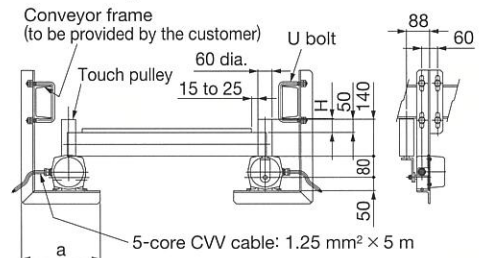

Model	Belt width	d dia.	W	A	H	E	L	T	m	n	Mass (kg)	Model	Belt width	H	a	Mass (kg)
HAB-MR-060052H	600	840	890	300	651	150	200	65	HAB-DR-060052H	600	13					
HAB-MR-075052H	750	1040	1090	370	797	70	75	HAB-DR-075052H	750	14						
HAB-MR-090052H	900	114.3	1190	1240	178	450	956	6	160	210	75	HAB-DR-090052H	900	53	300	14
HAB-MR-100052H	1000		1290	1340	500	1056	80		80	HAB-DR-100052H	1000	14				
HAB-MR-105052H	1050		1340	1390	520	1094	90		90	HAB-DR-105052H	1050	14				
HAB-MR-120052H	1200	139.8	1490	1540	210	600	1253	9	180	230	95	HAB-DR-120052H	1200	60	300	15
HAB-MR-135052H	1350		1640	1690	670	1392	100		100	HAB-DR-135052H	1350	15				
HAB-MR-140052H	1400		1730	1790	700	1450	105		105	HAB-DR-140052H	1400	15				
HAB-MR-150052H	1500	165.2	1830	1890	227	750	1550	280	340	340	145	HAB-DR-150052H	1500	78	320	16
HAB-MR-160052H	1600		1930	1990		800	1649		150		150	HAB-DR-160052H	1600			16
HAB-MR-180052H	1800		2220	2280		940	1938		215		215	HAB-DR-180052H	1800			16
HAB-MR-200052H	2000	2420	2480	1050	2157	235	235	330	390	215	235	HAB-DR-200052H	2000	365	365	16

Model Designation

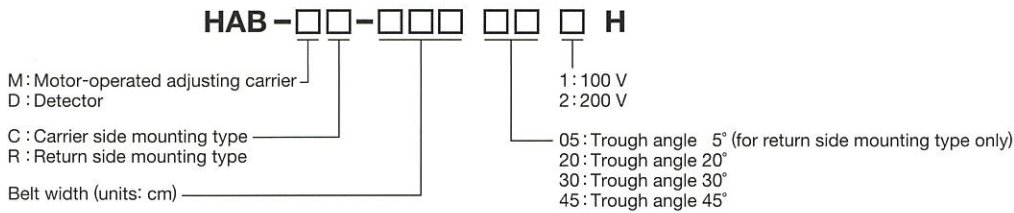

Connection Diagram (Hold Type Detectors) for Unidirectional Conveyor Application

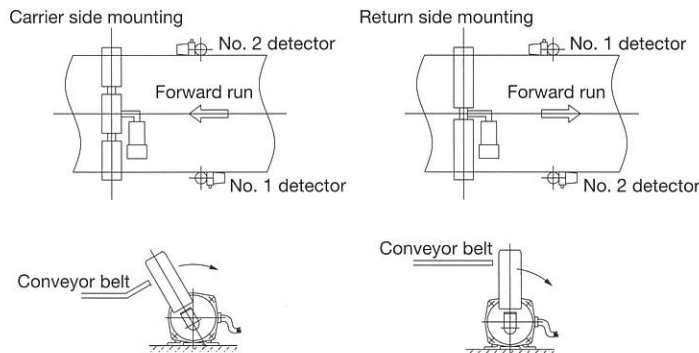
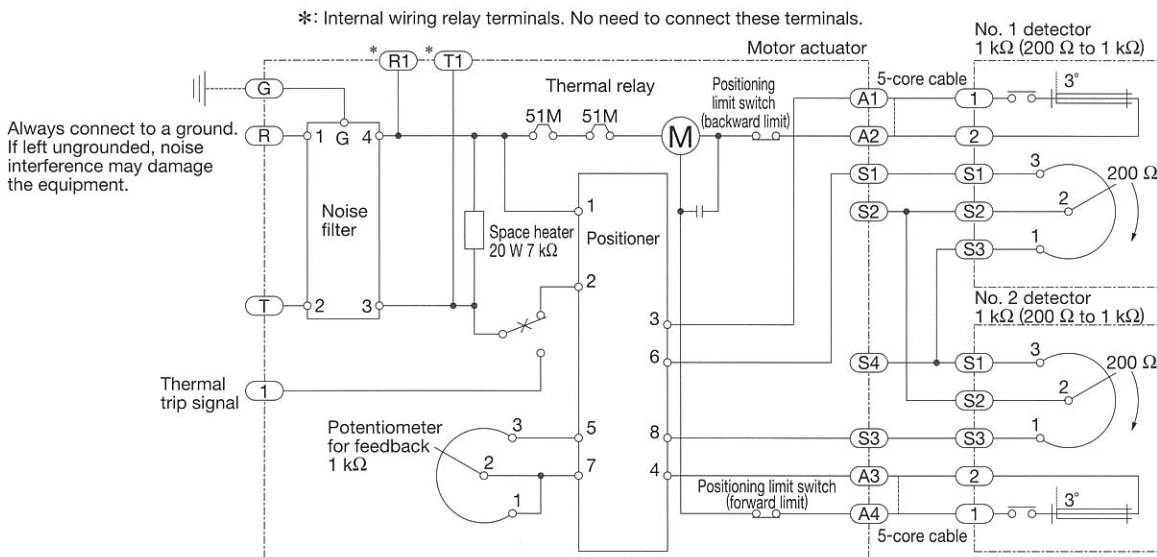

- Notes: 1. An auto reset type detector is also available.
2. If the wires between terminals A1 and A2 and terminals A3 and A4 are short-circuited in the above diagram, the motor will start running to move the Motor-Operated Adjusting Carrier back to the neutral position after the conveyor belt sway has been corrected and the deviation (sway) signal indicates 0 (zero).

Mounting positions

For forward run, mount the motor actuator and detectors as shown on the left.
For reverse run, reverse the positions of the No.1 detector and the No.2 detector.
Mount the detectors so that their lead outlets are positioned to the outside of the conveyor belt.



Caution
● Read the instructions to ensure correct and suitable application of products.
● Contact our nearest sales office when using our products for any systems used in situations which may be life threatening.

Specifications are subject to change without notice.
All Rights Reserved Copyright © 2017, Matsushima Machinery Laboratory Co., Ltd.

Distributor



Matsushima Measure Tech Co., Ltd.

HEAD SALES OFFICE / FACTORY
1-8-18, Norimatu Higashi, Yahatanishi-ku, Kitakyushu
807-0837, Japan
Tel: +81-(0)93-691-3731 Fax: +81-(0)93-691-3735

SEOUL LIAISON OFFICE
220, 2F Hyundai Knowledge Industry Center, 70, Dusan-ro, Geumcheon-gu, Seoul, Republic of Korea
Tel: +82-(0)2-852-3731 Fax: +82-(0)2-852-3734

SHANGHAI DAHONG MATSUSHIMA MACHINERY CO., LTD.
70 Hengchang Road, Dahong, Malu, Jiading, Shanghai 201801, China
Tel: +86-(0)21-59514138 Fax: +86-(0)21-59514139

https://www.matsushima-m-tech.com E-mail: info@matsushima-m-tech.com